

## TRI-BUILT® HOUSE WRAP INSTALLATION GUIDE

Before Applying TRI-BUILT® House Wrap Products:

Ensure that the wall substrate is flat and free of damage and foreign debris before TRI-BUILT® building wrap products are applied. In the event of existing moisture related wall problems, corrective measures need to be taken prior to installing TRI-BUILT® house wrap products. Contact a building envelope professional for detection and appropriate actions.

TRI-BUILT® house wraps are intended to perform as a secondary weather barrier behind a code complying exterior wall covering. TRI-BUILT® house wraps are not intended to function as a waterproofing membrane or primary line of defense against moisture infiltration.

Verify the intended application is compliant with local building codes.

### INSTALLATION - GENERAL

Ensure that TRI-BUILT® house wrap products are installed with the print facing out. TRI-BUILT® house wrap products should be installed after framing is complete and before windows and doors are installed.

Secure TRI-BUILT® house wrap products with non-corrosive roofing nails or staples spaced approximately 8" along the top and bottom plates and 24" apart in the field of the roll. Fasteners should be of sufficient length to penetrate framing or fastening substrate. Ensure that fasteners are properly driven; over and/or under-driven fasteners may cause pulling around the fastener or damage the building wrap material. Horizontal overlaps should be a minimum 2"; vertical overlaps should be a minimum of 6".

Joint Treatment: Application of sheathing tape is recommended at joints and TRI-BUILT® house wrap products using constant and adequate pressure to maximize adhesion.

TRI-BUILT® house wraps must be covered with a code-complying exterior wall covering within the period specified for each building wrap type.

# TRI-BUILT® HOUSE WRAP INSTALLATION GUIDE

## PREPARATION FOR WINDOW INSTALLATION

1. Make an inverted Y cut in the wrap at window rough opening. Make diagonal cuts at the top of the rough opening corners.
2. Fold the top flap upwards and temporarily tape in place to facilitate window installation. Fold the side and lower flap inward and secure in place to an interior framing member.

## FLASHING INSTALLATION - GENERAL

Make sure the surface is clean, dust free, smooth, and dry. (Note: do not apply over silicone caulk or other solvent based products).

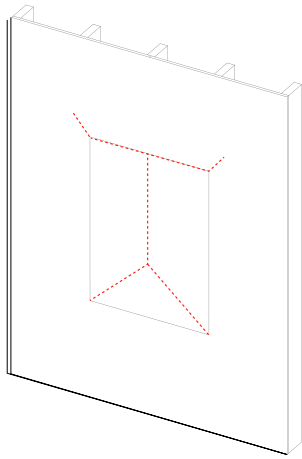

Figure 1: Inverted “Y” cut and diagonal cuts at window rough opening

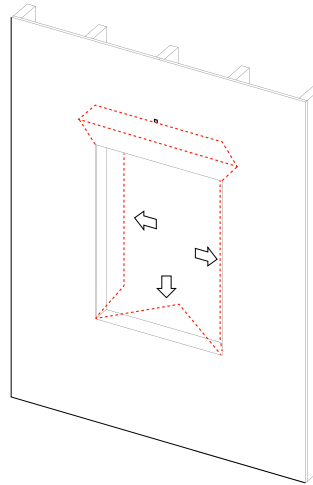

Figure 2: Top flap folded upwards. Jamb and sill flaps folding inward.

## FLEXIBLE FLASHING INSTALLATION - SILL DETAIL

1. Cut the desired length of flexible flashing with utility knife or scissors. Ensure the length of the flexible flashing is at least 12 inches wider than the width of the rough opening.
2. Remove 12” or more of the release film and center the tape over the area to be sealed.
3. Firmly press or roll the tape along the sill and up the jambs, working from the center of the rough opening outward. Allow the flexible flashing to overhang approximately 4 inches past the sill.
4. Firmly press or roll the flexible flashing into place on the surface of the building wrap. Fold the corner in place first, then work along the sill and jamb.

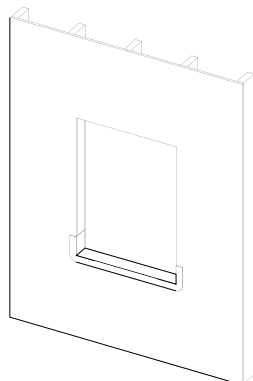
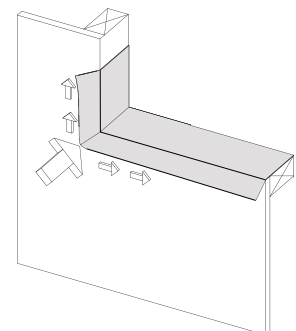

Figure 3: Flexible flashing finished sill application.

Figure 4: Direction of application of flexible flashing at sill and jamb intersection.



# TRI-BUILT® HOUSE WRAP INSTALLATION GUIDE

## CONVENTIONAL FLASHING AND FLEXIBLE FLASHING INSTALLATION - WINDOW INSTALLATION

1. Set the window per window manufacturer's installation instructions. Use appropriate size and gauge nail per window manufacturer's instructions. When sealant is required by the window manufacturer's installation requirements, applicable code or industry standard, use a solvent-free sealant and **DO NOT APPLY SEALANT TO BOTTOM WINDOW FLANGE.**

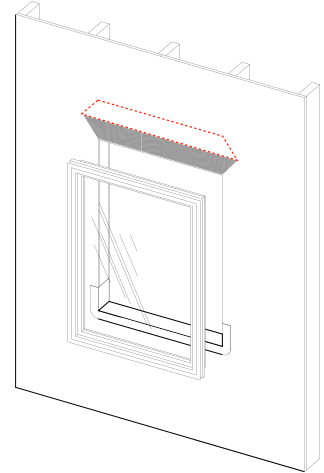

Figure 5: Window installation in accordance with window

## FLASHING INSTALLATION - JAMB DETAIL

1. Cut the desired length of the flashing with utility knife or scissors. Ensure the length of the flashing is sufficient to overlap the sill flashing and extend 6 inches or more past the top of the rough opening.
2. Remove 12 inches or more of the release film and center the tape over the area to be sealed.
3. Firmly press or roll the tape to the area being sealed. As you go along, pull more of the release film from the tape, exposing the adhesive surface, pressing down the tape and keeping the tape smooth. When through with the strip, roll it into place.

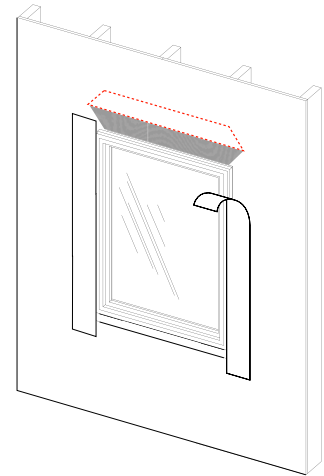

Figure 6: Flashing applied to jambs.

## FLASHING INSTALLATION - HEADER DETAIL

1. Cut the desired length of flashing with utility knife or scissors. Ensure the length of the flashing is sufficient to overlap the extend 6 inches or more past the jambs of the rough opening.
2. Remove 12 inches or more of the release film and center the tape over the area to be sealed.
3. Firmly press or roll the tape to the area being sealed. As you go along, pull more of the release film from the tape, exposing the adhesive surface, pressing down the tape and keeping the tape smooth. When through with the strip, roll it into place.
4. Remove the temporary tape on fold down the header flap of housewrap. Secure the header tape with flashing, or Sheathing Tape along the entire length of the window header.

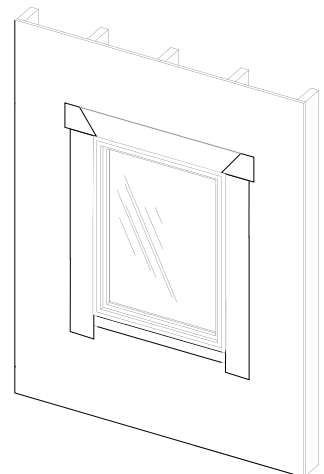

Figure 7: Flashing applied to window header.